

# A distributed, Grid-based analysis system for the MAGIC telescope

H. Kornmayer\*, M. Hardt, M. Kunze, Forschungszentrum Karlsruhe, Germany

C. Bigongiari, M. Mazzucato, INFN Padua, Italy

A. deAngelis, G. Cabras, A. Forti, M. Frailis, M. Piraccini, University of Udine, Italy

M. Delfino, PIC, Barcelona, Spain

## Abstract

The observation of high-energetic  $\gamma$ -rays with ground based air cerenkov telescopes is one of the most exciting areas in modern astro particle physics giving insight into active galactic nuclei (AGN), pulsars, supernova remnants, unidentified EGRET sources,  $\gamma$ -ray bursts and cosmology. The MAGIC telescope started operation at the end of 2003. The low energy threshold for  $\gamma$ -rays together with different background sources leads to a considerable amount of data. The data analysis will be done in different institutes spread across Europe. The production of Monte Carlo events including the simulation of Cerenkov light in the atmosphere is very computing intensive and another challenge for a collaboration like MAGIC. The current Grid technology widely deployed over 80 sites by LCG has recently proven to be mature and well adapted to set up a distributed computational and data intensive analysis system meeting the requirements of experiments like MAGIC. The basic architecture of such a distributed, Europe wide Grid system will be presented. First implementation results will be shown. This Grid might be the starting point for a wider distributed astro particle Grid in Europe.

## INTRODUCTION

The MAGIC telescope [1], located at the Instituto Astrofísico de Canarias on the La Palma island, in Spain, and operational since the end of 2003, was built to detect cosmic  $\gamma$ -rays at low energies around 30 GeV and above. This low threshold opens a wide physics potential covering the study of active galactic nuclei (AGN), pulsars, supernova remnants, unidentified EGRET sources,  $\gamma$ -ray bursts and cosmology. The telescope consists mainly of a  $\approx 230 \text{ m}^2$  mirror and a camera of 577 photomultiplier tubes (PMT). This camera is read out using a fast 300 MHz FADC system [2]. First observations of  $\gamma$ -ray sources are currently ongoing.

The collaborators of the MAGIC telescope are spread across Europe with the main contributors located in Germany (Max-Planck-Institute for Physics, Munich and Universities of Berlin and Würzburg, Italy (INFN and Universities of Padova, Siena and Udine) and Spain (Barcelona and Madrid). Most of these partners have access to a national Grid computing center. Such centers may be used to support the MAGIC partners in the operation of a distributed analysis system and in the development of Grid enabled software. The introduction of Grid technology

into the MAGIC collaboration would offer the possibility to study more sophisticated analysis methods.

In addition, a second MAGIC telescope will be built starting from 2005 and a distributed system with Grid middleware would provide a scalable environment of further upgrades.

## THE MAGIC TELESCOPE

In this section the basic principles of the MAGIC telescope and the main problems concerning computing are described.

MAGIC operates during moonless nights. The data acquisition system (DAQ) is designed for a permanent trigger rate of 1 kHz. Each pixel of the camera is split into two channels with different amplifications to increase the dynamic range of the photomultiplier tubes. A multi-level trigger system is used to select the 8-bit FADC values within a time range of 30 ns. All these values lead to a raw data stream of 70 GB/hour, and on average 500–600 GB/night of raw FADC data recorded per night. Concurrently the position of the camera is measured by a CCD system located in the center of the telescope dish. Additional data from the telescope control system or information from a weather station are also recorded. All this information have to be taken into account in the data analysis. The recorded data are mainly background events due to hadrons and muons. The analysis must reduce the number of these background events to get an enrichment of  $\gamma$ -rays in the source region. This enrichment is done by analyzing the image of the cosmic ray showers in the camera plane. During September 2004 the MAGIC telescope is still being commissioned to improve the potential of the detector. The threshold for  $\gamma$ -rays at the time was around 50 GeV with a trigger rate of  $\approx 200 \text{ Hz}$ . Images from different particles recorded with the photomultiplier tubes (PMTs) in the camera plane are shown in figure 1. The differences of the images allow an enrichment of  $\gamma$ -rays by applying the methods by Hillas [3]. This method is very effective at high energies.

The optimization of the  $\gamma$ -rays enrichment needs CPU intensive Monte Carlo studies. These Monte Carlo calculations are done with the air shower simulation program CORSIKA [4][5]. The mean time to simulate one air shower in the interesting energy range is about 6.5 s on a 2 GHz Pentium computer. The production of Monte Carlo events is currently running at CNAF on 5 dedicated double Xeon processors, with a buffer of 25 more processors [6]. On this cluster with around 70 CPUs the production rate is

\* harald.kornmayer@iwr.fzk.de

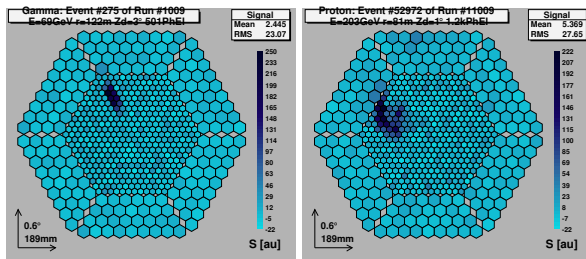

Figure 1: The view on the camera for events from different cosmic ray particles. The picture was created by integrating the FADC signal over time slices. The left hand pictures shows a event from a  $\gamma$ -ray, the right one a typical hadron picture. All these picture are based on CPU intensive Monte Carlo simulations.

about  $3 \cdot 10^5$  events/day. After the subsequent simulation of the detector only 7% of the  $\gamma$ 's and 0.1% of the protons produce a trigger and can be used for further studies; due to physical reasons this loss is unavoidable. The maximum production rate of triggered Monte Carlo events inside the MAGIC collaboration is  $\approx 150$  background events and  $\approx 10000$  gamma-ray events. But this standard procedure does not take into account the volatility of the atmospheric conditions and the starlight of the night sky background. In principle for each observation one must produce Monte Carlo events taking into account the measured atmospheric conditions and the night sky background light of the observed sky region. To get the same amount of triggered Monte Carlo events and measured real events for one night of observation (mean trigger rate 100 Hz and 8 h observation time) the whole Monte Carlo run would take between 288 days (only  $\gamma$ -rays) and 19200 days (background only). The production of the Monte Carlo events for an air Cherenkov telescope under realistic conditions is a great challenge because of the limited resources available. Therefore a good organisation of these computing resources and a systematic production strategy is required.

Also the analysis of the real data of the MAGIC telescope needs the introduction of new technologies. Different observation modes needs different analysis approaches: as an example, the analysis of on-source observations of a specific object is different from an all-sky survey to look for new  $\gamma$  sources. To study a dedicated source in detail, one needs easy access to data recorded during specific observation nights. For all-sky survey a fast access to all available data is necessary to get a result within a reasonable time. Therefore a good organisation of the data storage in combination with the usage of CPU is required.

## REQUIREMENTS

A distributed analysis system must fulfill a number of requirements to be really useful. The most important ones are summarized below:

- **Distributed**  
The collaborators are distributed in Europe and they want to build a common computing system for the collaboration.
- **Security**  
The access to the Grid resources must be restricted to the partners of the MAGIC collaboration.
- **Data access**  
The access to the different types of data (i.e. raw, pre-processed, analyzed, final results, ..) must be easy and served by the analysis system.
- **Accessibility**  
The access to the system must be easy and user friendly. There must be a single entry point for the user.
- **Availability**  
The system must run in a 24x7 environment.
- **Interactivity**  
The system must have a quick response time for users interacting with it.
- **Scalability**  
The system must be able to include more resources from inside the MAGIC collaboration. The connection of other external computing and storage resources must be possible. This is necessary to get a small run time for dedicated Monte Carlo or analysis jobs.

## ARCHITECTURE

The system will be based on common available middleware components. The main services will initially run in the computing centers such as GRIDKA (Germany), CNAF (Italy) and PIC (Spain). These centers will build the backbone of the distributed system as presented in figure 2. The system will be based on the middleware from the European Data Grid project [7], which is using the Globus toolkit [8] as the underlying software. With this middleware most of the requirements can be fulfilled.

The two services of the system are the MAGIC Monte Carlo Simulation (MMCS) and the MAGIC Analysis and Reconstruction Software (MARS). These services will run at all sites. Each of the two services will have its own scheduler (Resource Broker) running at CNAF or PIC. The schedulers will send the jobs to the different sites. The produced Monte Carlo data will be distributed as will the incoming real data from the telescope. The distribution and replication of the data will be based on the replica location service of the EDG project. The system will be accessed via a portal running at GRIDKA. The innovative approach of the Migrating Desktop with a roaming access and a job submission server developed within the CrossGrid project [10] is being evaluated.

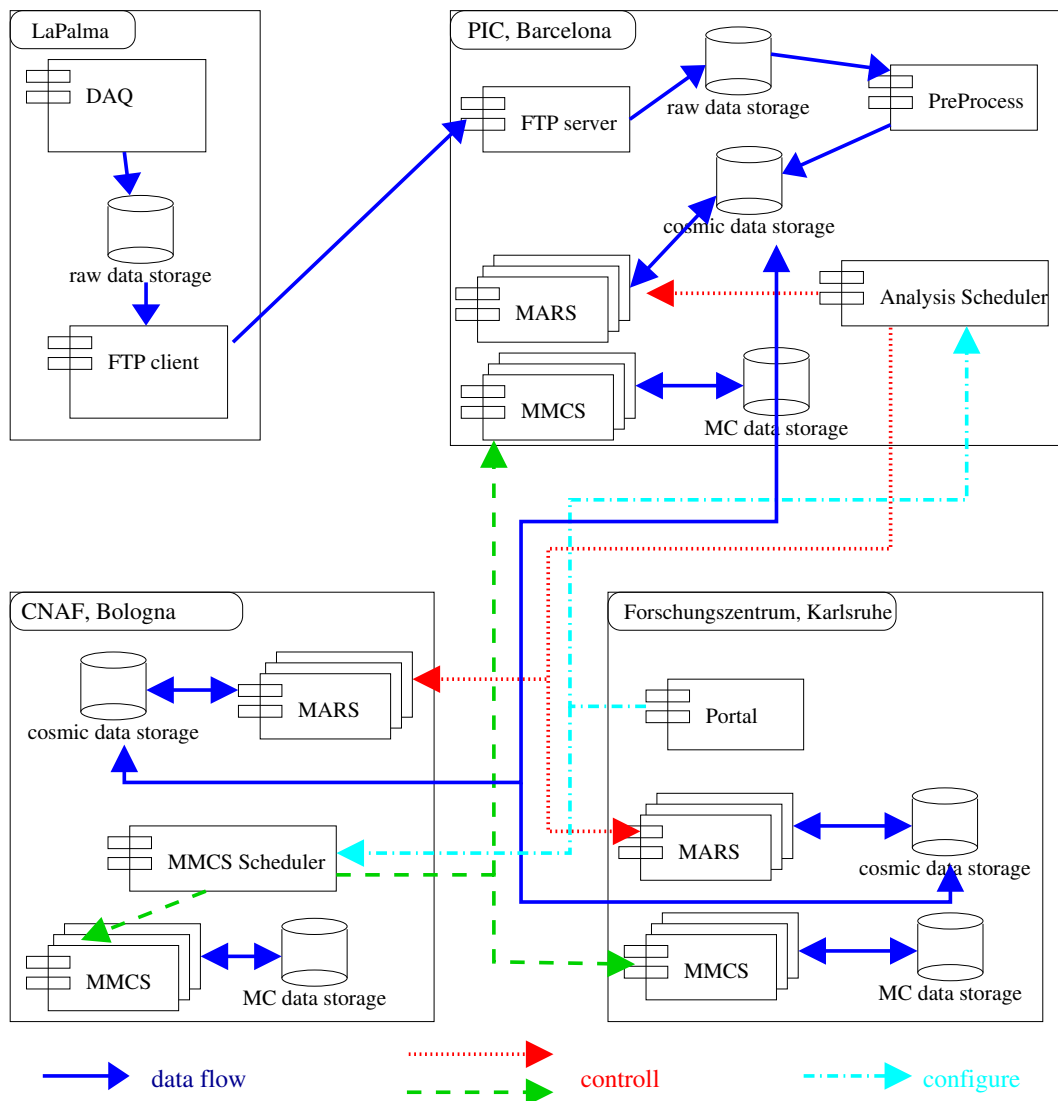

Figure 2: The design of the backbone for the distributed computing system shows the main components. The data from cosmic ray showers will be distributed. The corresponding dataflow is drawn as the solid lines. The main two computing tasks - analysis (MARS) and monte carlo production (MMCS) - are performed at all sites. They are controlled by two schedulers located at different sites. The access to this scheduler is available via a portal from every webserver.

The local computers from a MAGIC partner site can connect to the closest of the backbone nodes to contribute with their local computing resources.

## DEVELOPMENT

The development of the system was started in summer 2004. The development process will be done in the following different steps:

1. prototype for MMCS production  
 In the first phase the current production of Monte Carlo data will be moved to a Grid technology based system. Only very small changes on the current MMCS software are necessary. The first version of MMCS scheduler will be developed to get experience

with the distributed computing and storage environment. The deployment will be restricted to the backbone nodes. Also the first version of the portal will be implemented to demonstrate the benefit of a worldwide access to the system. The functionality of the security concept can be proven.

2. MMCS production and analysis prototype  
 In phase two the Monte Carlo production will start with the backbone nodes. The first MAGIC partner sites will be connected to the backbone to contribute to these computations. The transfer of raw data from the MAGIC telescope to the PIC in Barcelona will be set up. The preprocessing will be included and the first version of the distributed analysis software will

be developed. The analysis (MARS) will run only on the backbone nodes of the system. The portal will be extended to support the GUI for the analysis.

### 3. Analysis production and further developments

The analysis will be deployed to all local MAGIC partner sites. Each member of the collaboration can run their specific analysis on the Grid. The overall computing power will support the development of more sophisticated analysis methods. The development will be done on the same resources in a separate virtual environment to prevent interference with the production system. The connection of other Grid resources like commercial providers or other Grid centers can be tested to demonstrate the scalability of the design.

## FIRST RESULTS

The implementation of the first phase was started in August 2004. The development of the first prototypes concentrated on three use cases which are job submission, job monitoring and data management. The Monte Carlo program MMCS was successfully migrated to the Grid environment. Graphical user interfaces for all three use cases were developed to allow a user friendly access to the system from the very beginning. A dedicated runbook database was set up to control the progress of the Monte Carlo production.

First tests of the prototype implementation were done on the CrossGrid testbed [9]. This testbed consists of 16 sites in 11 European countries using LCG-2 as middleware. With 250 jobs submitted 250000  $\gamma$ -ray events were produced. Around 10% of the jobs failed due to a misconfiguration of the replica location service at two sites. The resubmission of the jobs was very easy due to the developed run database.

The EGEE project [11] started in April 2004 and will provide a Grid infrastructure for e-science in Europe. Therefore the EGEE project supports communities in the Grid domain. The proposal of the MAGIC collaboration was accepted by the EGEE generic application board in July 2004 as a generic application. The collaboration with EGEE started in September 2004. The virtual organisation for the MAGIC telescope is set up and first jobs will be sent to the EGEE infrastructure in October 2004. The first Monte Carlo data challenge of the MAGIC collaboration on a common grid infrastructure is scheduled for the beginning of 2005.

## FUTURE PROSPECT

The energy range of ground based astro particle physics ranges from  $10^{13}$ eV up to  $10^{20}$ eV. The simulation of the air showers in the atmosphere especially at high energies requires a lot of computing time. The setup of a general air

shower simulation services using the CORSIKA program can be used by all ground based air shower experiments.

The understanding of cosmic ray sources like AGN or supernovae is based on measurements from various energy ranges measured with different experiments. A Grid environment might offer data-mining functionalities to combine the results from different experiments.

The astro particle physics community can benefit from the usage of Grid technologies. There must be a coordinated effort to set up a Grid for astro particle physics. The proposed system for MAGIC might be a starting point for that ASTROPA Grid.

## SUMMARY

The analysis of data from the MAGIC telescope needs computing and storage resources. The collaborators are based around Europe. A design of a distributed system for analysis and Monte Carlo production for the MAGIC telescope exists. The project can be realized with three Grid centers in Italy, Spain and Germany together with the main partners of the MAGIC telescope on a reasonable timescale. The system can be ready when the MAGIC telescope will reach the full observation potential within the year 2005.

The proposed Grid will show the benefit of Grid technology in the field of astroparticle physics. Many other experiments to observe cosmic rays in the energy range between  $10^{13}$ eV up to  $10^{20}$ eV are being planned. The proposed system might be the starting point for a wider distributed Grid for astro particle experiments.

## REFERENCES

- [1] E. Lorenz, 1995, Fröhjahrstagung Deutsche Physikalische Gesellschaft, March 9-10
- [2] J. Cortina et al., 2002, T10, Proceedings of the int. Symposium "The Universe in Gamma-rays", University of Tokyo, Kashiwa, September 22-28
- [3] A.M. Hillas, 1985, Proc. 19th ICRC (La Jolla), vol. 3, p. 445
- [4] J. Knapp, D. Heck, 1998, EAS Simulation with CORSIKA, A User's Manual
- [5] J. N. Capdevielle et al., 1992, The Karlsruhe Extensive Air Shower Simulation Code CORSIKA, KfK report 4998
- [6] M. Piraccini, Master Thesis at the University of Udine (2004)
- [7] The DataGrid Project, <http://eu-datagrid.web.cern.ch>
- [8] The Globus toolkit, <http://www.globus.org>
- [9] The CrossGrid Project, <http://www.crossgrid.org>
- [10] M. Bubak et al., 2003, Architecture of the Grid for Interactive Applications, in: Sloot, P. M. A., et al. (Eds.), Proceedings of Computational Science - ICCS 2003, International Conference Melbourne, Australia and St. Petersburg, Russia, June 2003, vol. I, no. 2657, Lecture Notes in Computer Science, Springer, pp. 207-213
- [11] The EGEE project, <http://www.eu-egee.org>